

PRODUCT INFORMATION PACKET



Model No: 194014.00
Catalog No: 194014.00
30 HP Washdown, 3 phase, 3600 RPM, 208-230/460 V, 286TC Frame, TEFC
Paint Free IEC Washdown Motors



Regal and Leeson are trademarks of Regal Beloit Corporation or one of its affiliated companies.
©2019 Regal Beloit Corporation, All Rights Reserved. MC017097E

The Regal logo is positioned in the bottom right area of the page. It features the word "REGAL" in a white, bold, sans-serif font, set against a dark grey, trapezoidal background. This logo is placed on a vertical blue decorative bar that has a halftone dot pattern and tapers from top to bottom.



Nameplate Specifications

Output HP	30 Hp	Output KW	22.4 kW
Frequency	60 Hz	Voltage	208-230/460 V
Current	76.0-68.0/34.0 A	Speed	3550 rpm
Service Factor	1.15	Phase	3
Efficiency	91.7 %	Power Factor	90
Duty	Continuous	Insulation Class	F
Design Code	B	KVA Code	G
Frame	286TC	Enclosure	Totally Enclosed Fan Cooled
Thermal Protection	No	Ambient Temperature	40 °C
Drive End Bearing Size	6310	Opp Drive End Bearing Size	6212
UL	Recognized	CSA	Y
CE	N	IP Code	55

Technical Specifications

Electrical Type	Squirrel Cage Inverter Rated	Starting Method	Line Or Inverter
Poles	2	Rotation	Reversible
Resistance Main	.3 Ohms	Mounting	Rigid base
Motor Orientation	Horizontal	Drive End Bearing	Ball
Opp Drive End Bearing	Ball	Frame Material	Stainless Steel
Shaft Type	T	Overall Length	27.95 in
Shaft Diameter	1.875 in	Shaft Extension	4.64 in
Assembly/Box Mounting	F1/F2 CAPABLE		

This is an uncontrolled document once printed or downloaded and is subject to change without notice. Date Created:01/11/2019

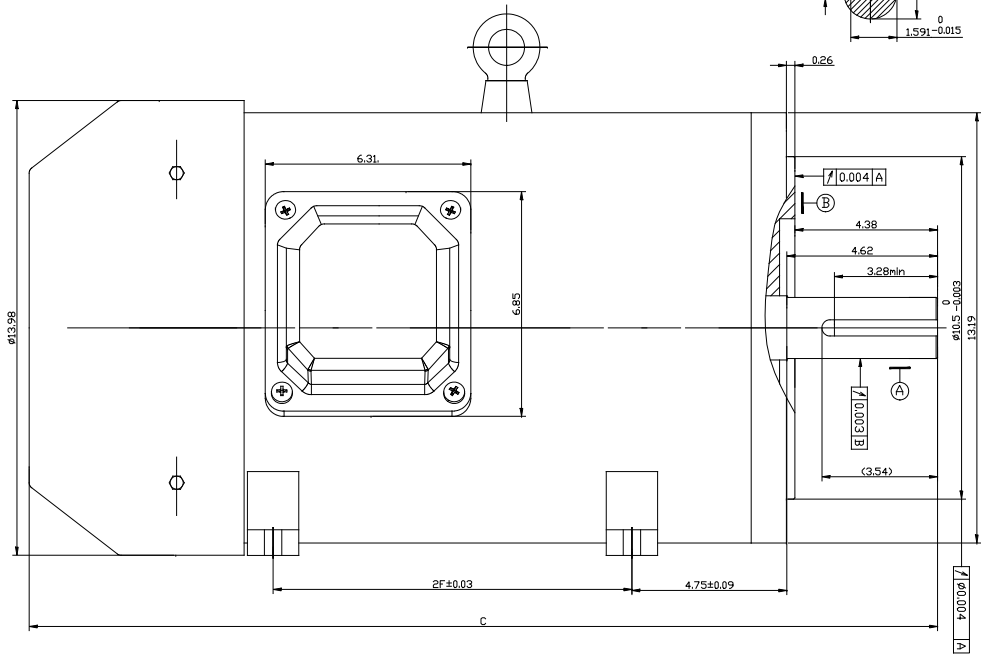
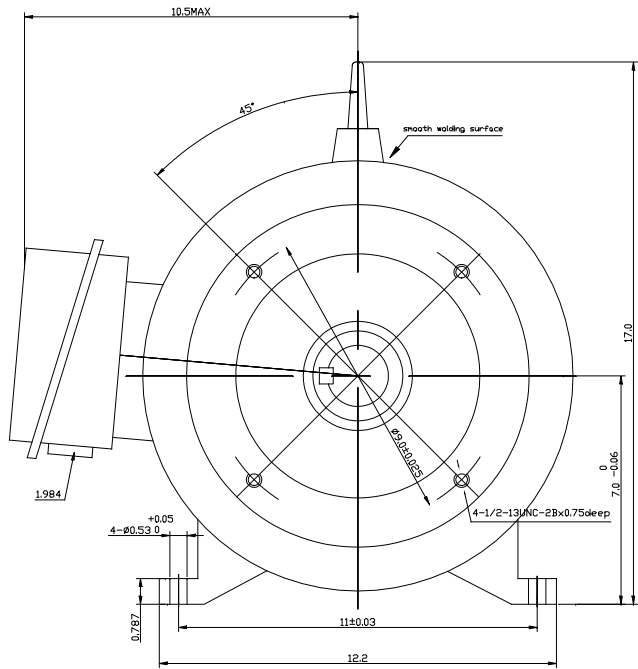

LEESON PART NO.	FRAME	HP	VOLTS	Hz	RPM	MOUNTING	S.F	DUTY	ENCL.	PH	2F	C
194012.00	284TC-2	25	230/460	60	3600	RIGID+C FLANGE	1.15	CDNT.	TEFC	3	9.5	26.97MAX
194013.00	284TC-4	25	230/460	60	1800	RIGID+C FLANGE	1.15	CDNT.	TEFC	3	9.5	26.97MAX
194014.00	286TC-2	30	230/460	60	3600	RIGID+C FLANGE	1.15	CDNT.	TEFC	3	11.0	27.95MAX
194015.00	286TC-4	30	230/460	60	1800	RIGID+C FLANGE	1.15	CDNT.	TEFC	3	11.0	27.95MAX

NOTE:
1. TO REFERENCE DW DRAWING COPW202.709

		TOLERANCES UNLESS SPECIFIED		DRAWN
		DEC.	METRIC	
		X	± 2.5	APPD
		.XX	± .76	SCALE
B	NOTE ADDED	NK	9/25/18	REF
A	RELEASED FOR PRODUCTION ECO-0126037	WGJ	6-27-17	PREV
NO.	REVISION	BY & DATE	CHK ANG	
THIS DRAWING IN DESIGN AND DETAIL IS OUR PROPERTY AND MUST NOT BE USED EXCEPT IN CONNECTION WITH OUR WORK ALL RIGHTS OF DESIGN AND INVENTION ARE RESERVED THIS IS AN ELECTRONICALLY GENERATED DOCUMENT - DO NOT SCALE THIS PRINT		RFP		
		DIST		
		CAD FILE SS620848		SIZE B
		DRAWING NO. SS620848		REV. B
		TITLE REGAL - BELOIT CORPORATION		
		TITLE OUTLINE SST 280 FRAME		
		FINISH		